

Open design, flexible mounting

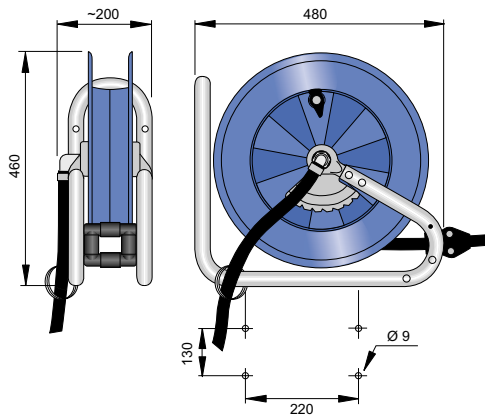

Nederman Series 893

A medium sized hose reel with open design. Versatile and easy-to-mount in industrial and workshop environments.

- Open design for easy cleaning and servicing.
- Unique stand design offers mounting flexibility.

Anti-corrosion and stainless steel models available (see pages 11 and 12).

Weight incl. hose: 13 – 16 kg

Material recycling: 100 %

Use for	Max. working pressure MPa (psi)	Distribution hose		Connection hose*	Hose material	Hose type (see page 17)	Reel with hose Part no.	Reel without hose Part no.
		Int. Ø mm (in)	Length m	Int. Ø mm (in)				
Air / Water	1.5 (220)	10 (3/8)	15	12.5 (1/2)	Rubber	B	30800693	30800393
		12.5 (1/2)	10		Rubber	B	30800893	30800793
Water – food grade hose	2.0 (290)	12.5 (1/2)	10	12.5 (1/2)	Rubber	E	30801093	–
HP water	25 (3625)	10 (3/8)	15	10 (3/8)	Rubber	G	30801893	30801793
Oil	7.5 (1090)	12.5 (1/2)	10	12.5 (1/2)	Rubber	I	30801693	30801593
Grease	35 (5075)	6 (1/4)	15	6 (1/4)	Rubber	J	30802693	30802593

* Connection hose = 1 m long